

Houseboat "POHODA"

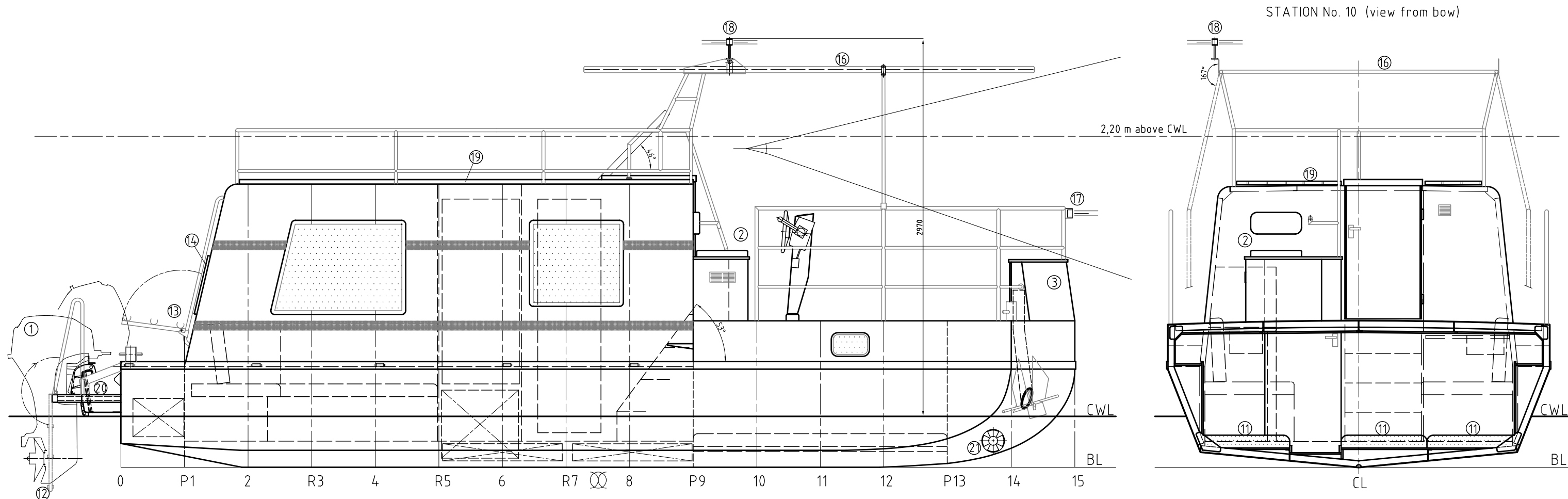

FRESH WATER: 2 x 97 lit.
 GREY WATER: 2 x 170 lit. STATION SPACING: a = 500 mm BERTH: 5 - 7
 GASOLINE: 90 lit. HULL MATERIAL: STEEL - STN 11 375 STANDING HEIGHT IN SALOON / FORCABIN: 1,92 / 0,81 m

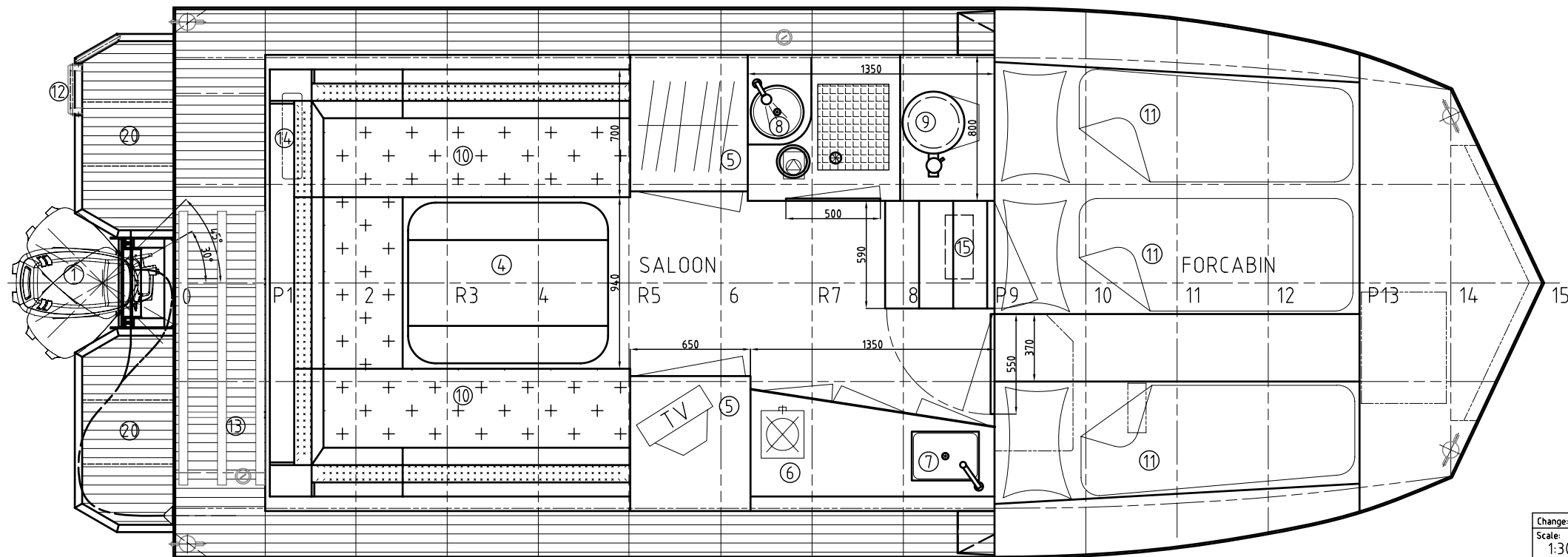

- LEGEND:**
- 1) OUTBOARD ENGINE 5,9 - 25,7 kW (8 - 35 k)
 - 2) WHEEL HOUSE
 - 3) BOX FOR ANCHOR WINDLASS AND ELECTRIC GENERATOR
 - 4) TABLE (TELESCOPIC)
 - 5) COUNTER / WARDEROBE
 - 6) OWEN
 - 7) SINK
 - 8) WASH BASIN WITH SHOWER
 - 9) TOILETTE WITH HAND PUMP
 - 10) U-SHAPE BENCH / BERTH (2 - 4)
 - 11) BERTH IN FORCABIN (3)
 - 12) SWIM LADDER (FOLDING)
 - 13) BICYCLE CARRIER (FOLDING)
 - 14) HATCH 415x415
 - 15) AIR HEATING
 - 16) FOLDABLE ROOF
 - 17) NAVIGATION LIGHTS (RED 112,5° / GREEN 112,5°)
 - 18) NAVIGATION LIGHT (WHITE 360°)
 - 19) WOODEN GRID ON THE ROOF
 - 20) SWIMMING PLATFORM
 - 21) BOW THRUSTER (NOT IN STANDARD)
- RCD DESIGN CATEGORY: D

L_{MAX} = 8,40 m
 L_H = 7,50 m
 L_{CWL} = 7,35 m
 B_H = 2,94 m
 B_{MAX} = 3,00 m
 H_{tr} = 0,79 m
 T_C = 0,40 m
 T_{MAX} = 0,52 m
 H_{CWL} = 2,20 m
 G = 5,49 t
 N = 1,47 t
 Crew max. 12

ALL RIGHTS OF THIS DESIGN AND DETAILS ARE RESERVED.
 It is sent to you for personal use authorized in writing by our firm.
 Copy or inspection by a third party or any work other than authorized is forbidden and will be considered an infringement of these rights.

Change:	Notes:	Date:	Name:
Scale:	Signature:	Date:	Name:
1:30 (A3)		10/05	J. MANDL
MANDL - Living on Water, s.r.o.		Technol. group:	
A. Gverkovce 1 851 04 Bratislava Slovak Republic IČO: 44 809 841 DIČ: 2022837036		Houseboat "POHODA"	
T: +421 2 207 33 009 M: +421 903 233 009 E: info@mandl-low.sk W: www.MANDL-Low.sk		General arrangement plan	
		Name:	
		GENERAL ARRANGEMENT	
		Drawing number:	
		02-01.04/05	
		No of sheets	Sheet
		1	1